

EXT Series

800lbs Water Proof Electromagnetic Lock

Model EXT325-SLCG-A (Monitored Version)

DESCRIPTION

800lbs Water Proof EM locks were designed as such to be unaffected / resisting the ingress of water under specified condition with its fully sealed electronics incased with stainless steel. This EM Lock series is fitted with cable gland. Suitable for outdoor application and harsh climate.



FEATURES & SPECIFICATION



Life Safety Applications



Zero Residual Magnetism



Low Energy Consumption



Cost Savings

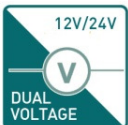

12/24Vdc Selectable



Fully Sealed Electronics

Model	EXT325-SLCG-A
Features & Spec.	
Lock Status Monitoring	Reed Switch
Holding Force	Up to 800lbs
Magnet Size	220 X 46 X 30 mm
Armature Size	182 X 44 X 12 mm
Current Drain	460mA±10%/12Vdc 230mA±10%/24Vdc
Operating Temperature	(-10 to 55) °C (14 to 131) °F
Housing Finishing	Stainless Steel Housing
Est. Weight	2.7kg

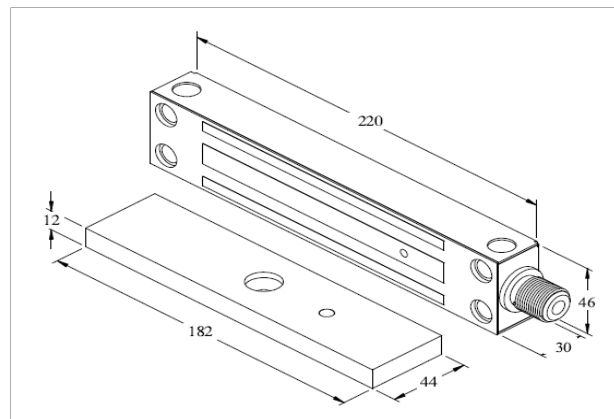

EXT Series

800lbs Water Proof Electromagnetic Lock

STANDARD INSTALLATION DIAGRAM

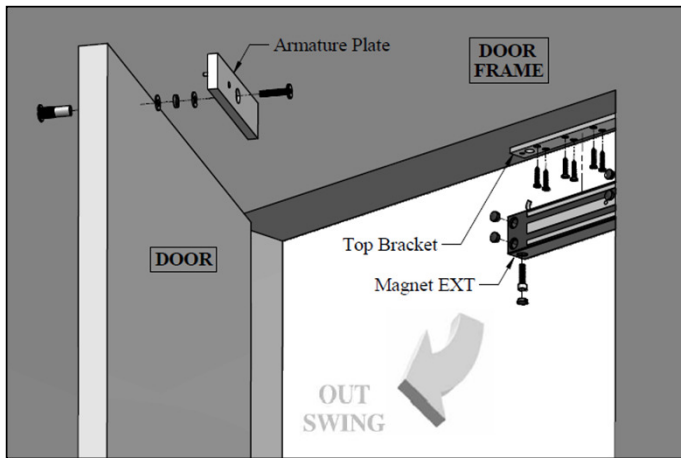

Explode View

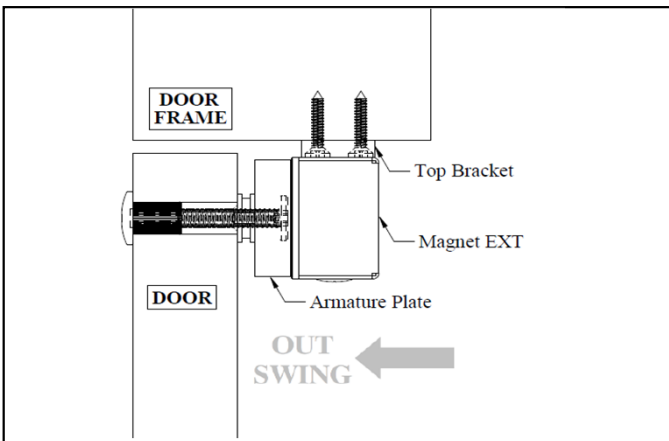

Side View

WIRING DIAGRAM

Wiring Instruction Diagram EXT

WIRING INSTRUCTIONS

IMPORTANT!
Before the power supply is switched on,
set the wiring correctly.

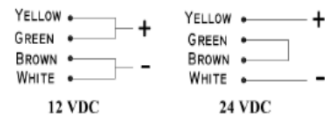

REED SENSOR CONTACT



OPTIONAL - BRACKET SELECTION

LS-EXT325

Z-325